

Features

- Compact, fully enclosed splash proof design
- Over 1,000,000 duty cycles
- High power density

Applications

- Wind turbine
- Automotive
- Heavy duty machinery
- Energy storage system

General Specification



Items	Characteristics
Nominal Capacitance	500 F
Capacitance Tolerance	0% / +20%
Rated Voltage	16 V
Surge Voltage	17 V
ESR, DC	1.8 mΩ
Maximum Continuous Current (Δ T=15°C)	100 A
Maximum Continuous Current (Δ T=40°C)	160 A
Maximum Peak Current, 1 sec.	2000 A
Operating Temperature Range	-40 °C to +65 °C
Storage Temperature Range	-40 °C to +70 °C
Environment Humidity	≤90%RH
Weight	5.7 kg
Power Terminals	M8/M10
Recommended Torque - Terminal	20/30 Nm
Vibration Specification	IEC 255-21-1
Shock Specification	IEC 255-21-2
Environmental Protection	IP54
Temperature Monitoring	NTC Thermistor
Usable Power Density (Pd)	2,994 W/kg
Impedance Match Power Density (Pmax)	6,237 W/kg
Gravimetric Energy Density (Emax)	3.1 Wh/kg
Stored Energy	17.8 Wh
Temperature Performance (-40°C to 65°C)	ΔC ≤ 5% of initial measured value@ 25°C ESR ≤ 150% of specified value
High Temp. Life (1,500 hours @ 65°C, Rated Voltage)	ΔC ≤ 20% of initial measured value ESR ≤ 200% of specified value
Room Temp. Life (10 years @ 25°C, Rated Voltage)	ΔC ≤ 20% of initial measured value ESR ≤ 200% of specified value
Cycle Life (1,000,000 cycles between V _R and 1/2 V _R)	ΔC ≤ 20% of initial measured value ESR ≤ 200% of specified value
Shelf Life (25°C, uncharged)	4 years
Factory High-Pot Test	DC 2,500 V
Typical Thermal Resistance	0.8 °C/W
Typical Thermal Capacitance	4,400 J/°C

Difference Parameter List

Items	MCP0500C0-0016R0SHC	MCP0500C0-0016R0SHZ
Balancing	Equalization circuit	Passive
Cell Voltage Monitoring	Overvoltage Alarm	--
Leakage Current	5.2 mA (25°C, after 72h)	170 mA

Pin Definition
MCP0500C0-0016R0SHC

Pin Number	Wire Color	Definition	Output
1	Black	GND	
2	Red	Overvoltage Alarm	High - Inactive Low - Active
3	Void	Void	
4	Green	Temperature	

Pin Definition
MCP0500C0-0016R0SHZ

Pin Number	Wire Color	Definition	Output
1	Black	GND	
2	Void	Void	
3	Void	Void	
4	Green	Temperature	

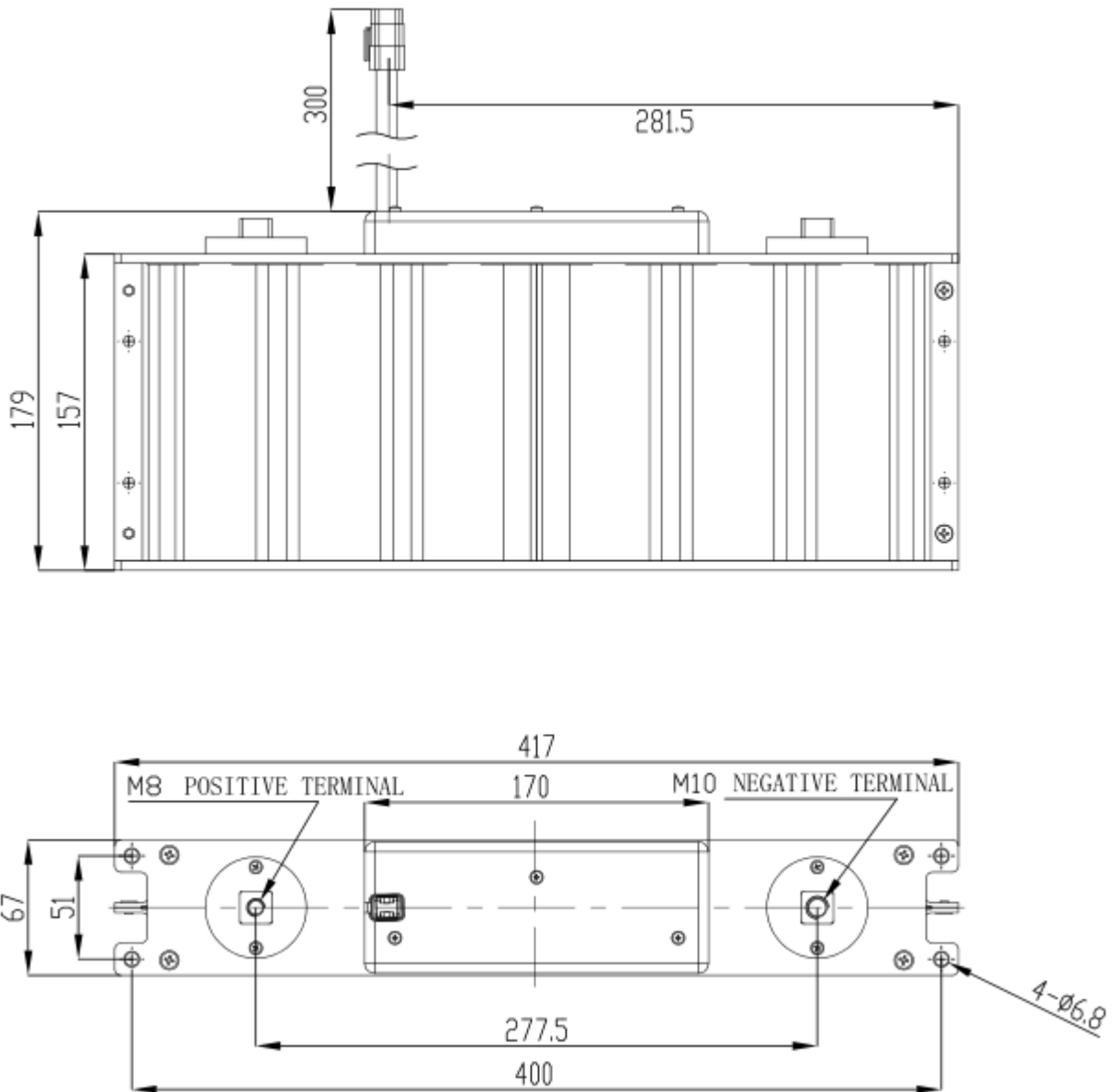
Dimensions

Part Number	Dimension (mm)		
	L (±1mm)	W (±1mm)	H (Max)
MCP0500C0-0016R0SHC MCP0500C0-0016R0SHZ	417	67	179